



CT23PO06

Double/Single DIN Fitting Kit for Porsche Vehicles



IN THE KIT

- Double DIN Fascia Bracket
- Radio Brackets
- HVAC trim panel with Pocket
- 8x Screws

APPLICATION

Note: Application data is subject to change at any time

Porsche 911 (996)	1999 - 2005
Porsche Boxster (986)	1997 - 2004

Note: for vehicles with & without navigation. Vehicles without factory navigation - HVAC relocation vehicles must have a lower console.

FEATURES

- Allows for the installation of a single/double DIN aftermarket stereo
- Includes mounting brackets and fitting accessories
- Finished in matt black to match vehicle dashboard

DISCLAIMER

The information provided in this document is subject to change without notice due to manufacturer changes and/or improvements to the product/s. This instruction manual is based on documented data and research. The manufacturer of this product cannot be held responsible for any changes made to the vehicle by the manufacturer or damages that may occur through the installation of this product in accordance with the steps outlined herein.

PRIOR TO INSTALLATION

Read the manual prior to installation. Technical knowledge is necessary for installation. The place of installation must be free of moisture and away from heat sources. Please ensure that the correct tools are used during the installation to avoid damage to the vehicle or product. **Connects2 can not be held responsible for the installation of this product.**

INSTALLATION GUIDE

DASH DISASSEMBLY - VEHICLES WITHOUT NAV

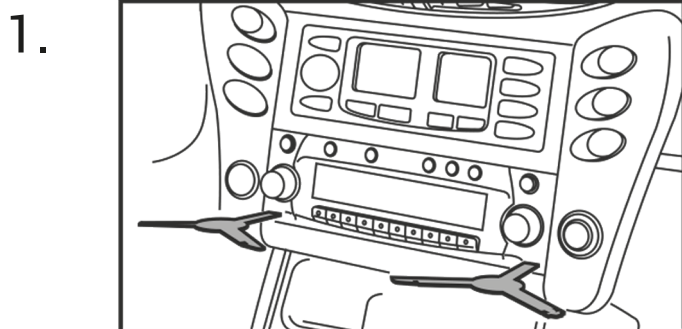

Begin by inserting a set of radio release keys into the appropriate holes to release the radio. Once the radio is out, disconnect all of the wiring.

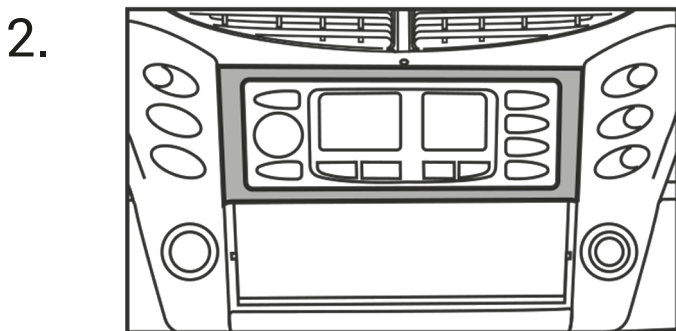

Using a panel removal tool, carefully remove the trim panel that surrounds the HVAC unit.

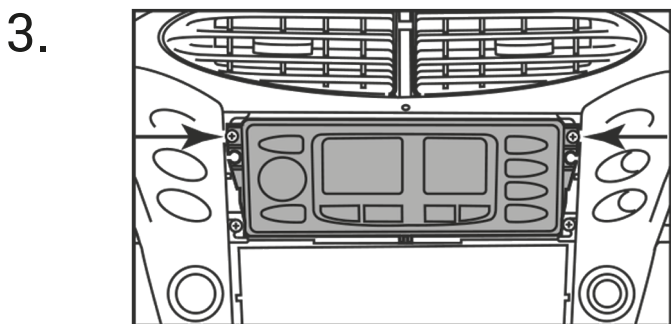

With the trim panel out of the way, proceed to undo the 2x phillips screws that hold the HVAC in place. Once done, remove and disconnect the HVAC unit.

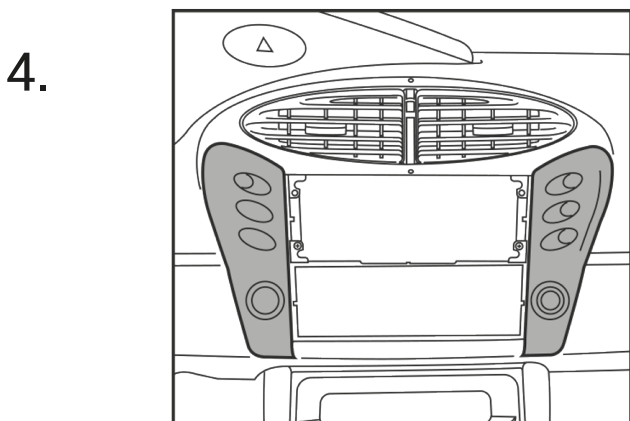

Using a panel removal tool, unclip the 2x switch panels either side of the radio opening and disconnect them in the process.

INSTALLATION GUIDE

DASH DISASSEMBLY - VEHICLES WITHOUT NAV

5.

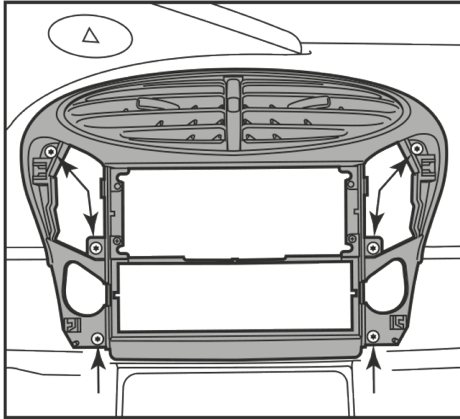

With the side button panels removed, proceed to undo the 6x T-20 Torx screws that surround the radio frame assembly and remove it completely.

6.

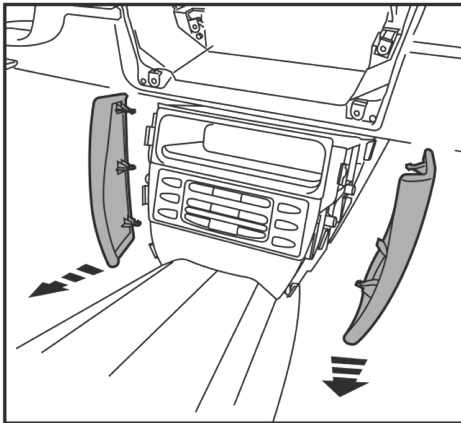

Using a panel removal tool, unclip the 2x trim panels that surround the main lower console.

7.

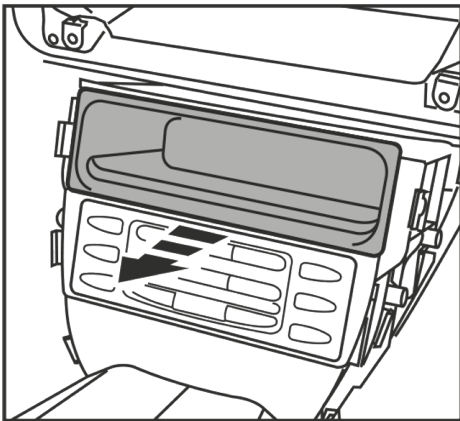

With the side panelling out of the way, simply pull and remove the factory CD tray/pocket.

For models equipped with a DSP controller:

8.

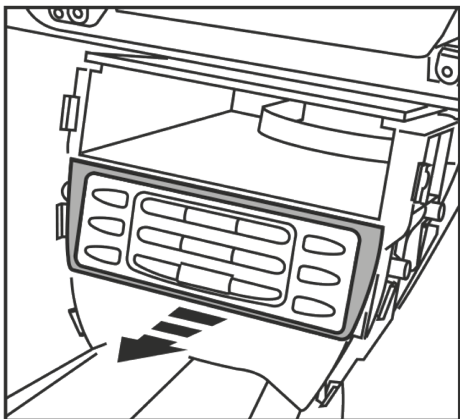

The controller will need to be relocated to the inside of the lower dash. The controller must stay connected in order for the factory amplifier to function.

Using a panel removal tool, unclip the trim surrounding the DSP controller.

INSTALLATION GUIDE

DASH DISASSEMBLY - VEHICLES WITHOUT NAV

For models equipped with a DSP controller:

9.

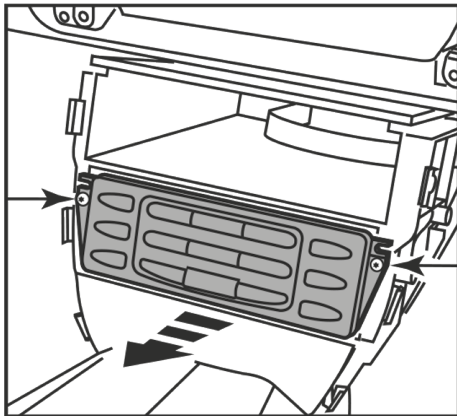

With the trim panel removed, proceed to undo the 2x T-20 Torx screws that hold the controller in place. Once free, remove and relocate within the lower dash.

DASH DISASSEMBLY - VEHICLES WITH NAV

1.

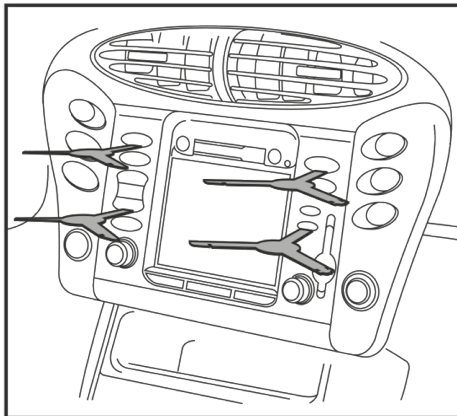

Begin by inserting 2x sets of radio release keys into the appropriate holes to release the radio. Once the radio is out, disconnect all of the wiring.

2.

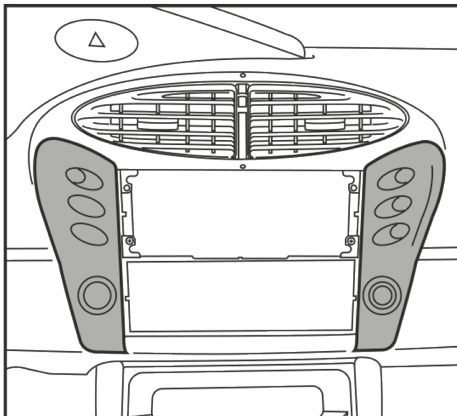

Using a panel removal tool, unclip the 2x switch panels either side of the radio opening and disconnect them in the process.

3.

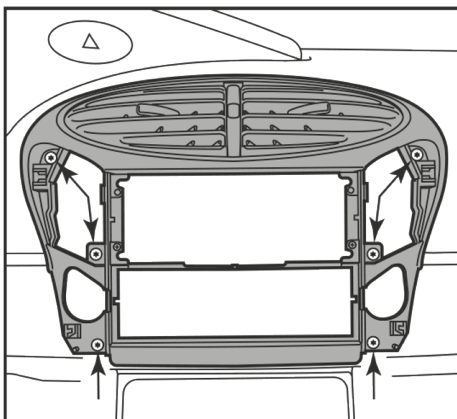

With the side button panels removed, proceed to undo the 6x T-20 Torx screws that surround the radio frame assembly and remove it completely.

INSTALLATION GUIDE

DASH MODIFICATION

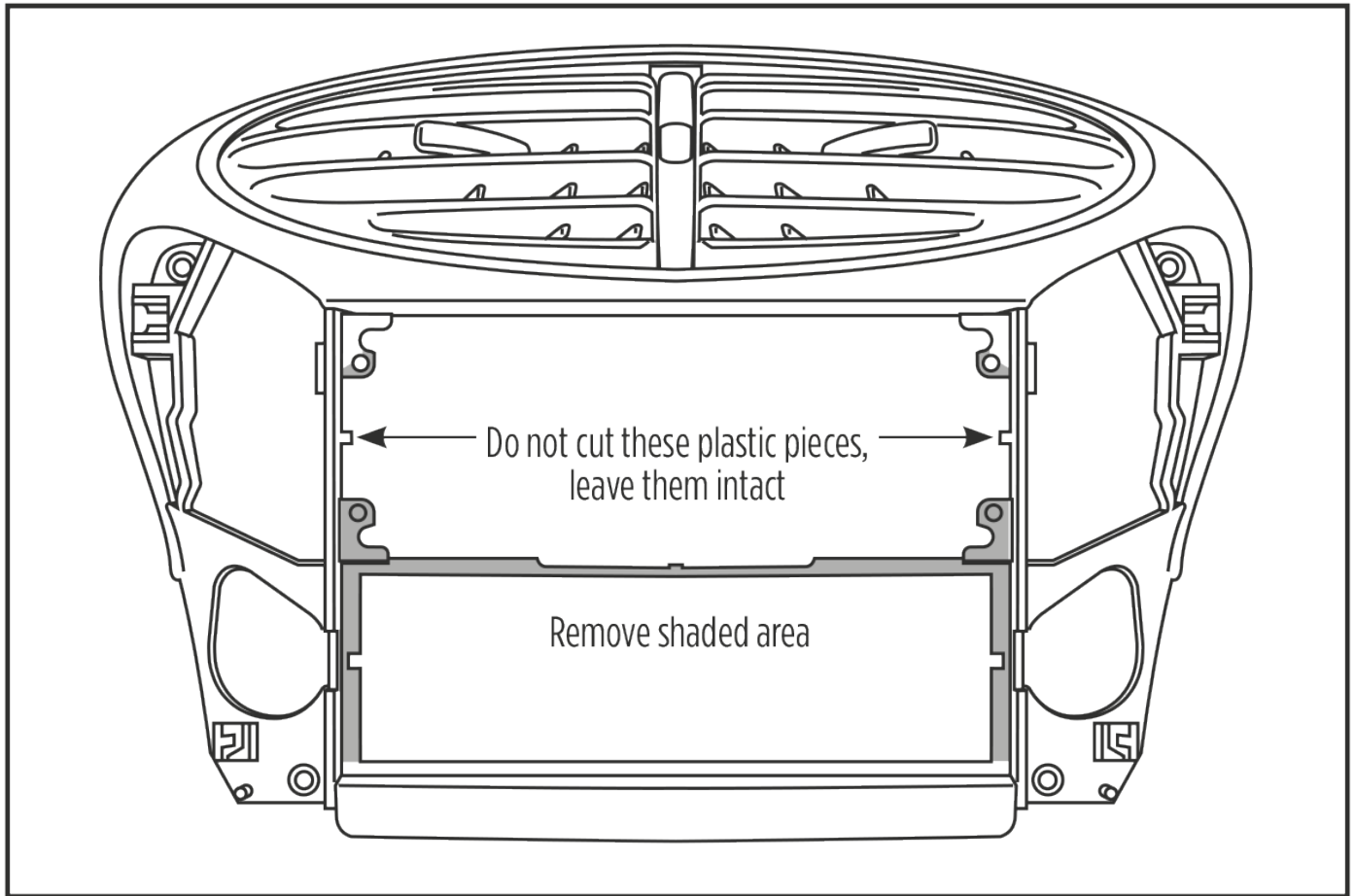

The highlighted area above needs to be cut out of the dashboard in order for a double DIN unit to sit correctly. When doing this, ensure that you do not cut the 2x plastic notches.

When performing a modification of the vehicle, always ensure to measure where the stereo will sit and take due care when performing cuts to the vehicle. Connects2 always promote the use and expertise of professional installers. Connects2 will not be held responsible for any damage to the vehicle.

INSTALLATION GUIDE

DASH ASSEMBLY

1.

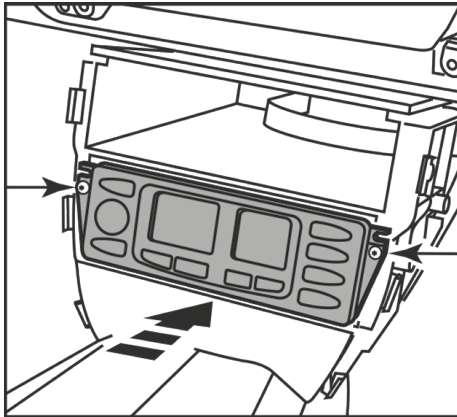

Feed the climate control wiring down through the main fascia opening to the lower console. Once fed through, reconnect the HVAC panel and secure the panel in place using the pre-existing screws.

2.

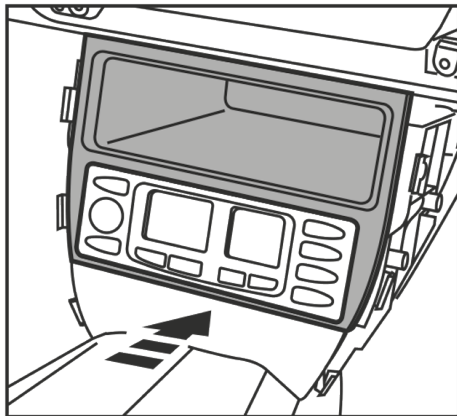

With the HVAC unit installed, fit the new Trim Panel with Pocket HVAC over the top and re-attach both the lower side panels.

INSTALLATION GUIDE

KIT ASSEMBLY

1.

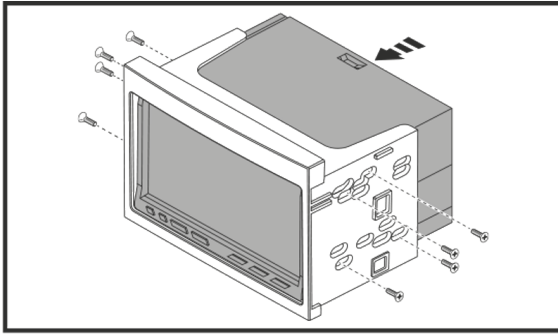

Take the aftermarket head unit and slide this into the back of the Double DIN Fascia Bracket. Once seated/aligned appropriately, screw it into place using the screws provided with your head unit.

2.

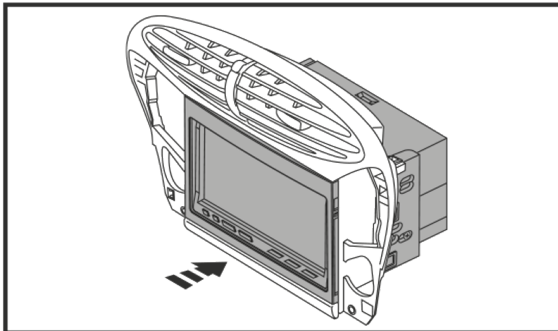

With the bracketry attached to the aftermarket head unit, slide this through the front of the factory fascia panel.

3.

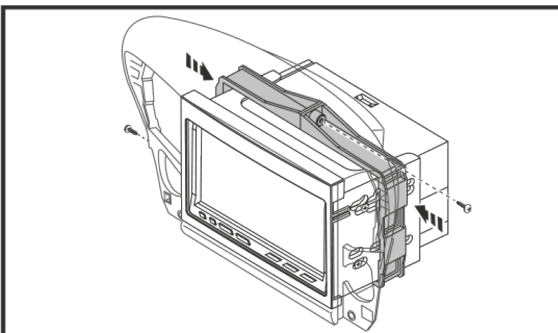

When seated correctly, place the set of Radio Brackets around the radio housing and tighten them using the screws provided with the kit. Once this is done, attach all the wiring to the back of the unit and reassemble the dashboard in reverse order of assembly.

NOTES
