

For information about other American International automotive accessories visit our website at:

<http://www.americaninternational.net>



American International

Car Stereo Installation Kits & Accessories

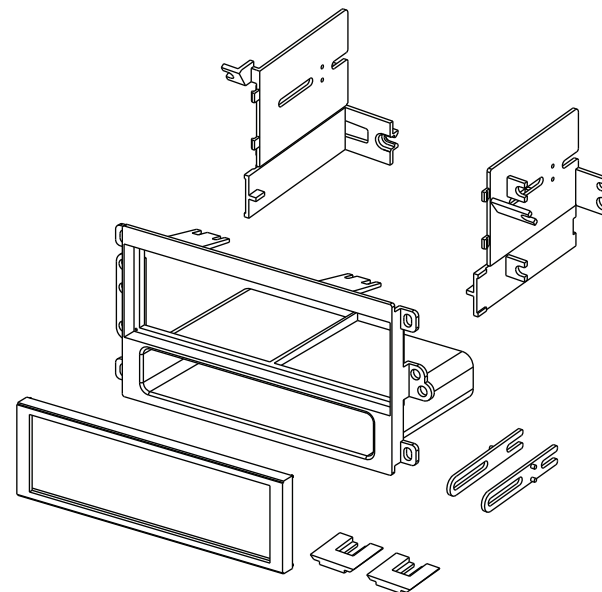

GMK420 Mounting Kit



American International

Automotive Products Division

1040 Avenida Acaso • Camarillo, CA 93012, U.S.A.

USA Sales (800) 336-6500

Canada Sales (888) 922-3006 • USA Fax (805) 388-7950

CUSTOMER HELP LINE

8am-4:30 P.S.T. Monday-Friday Except Holidays

USA 800-323-4329 • Canada 800-245-8777

iGMK420

VEHICLE APPLICATIONS

*Fits oversized Delco Radio dash opening only

Buick		2007	SILVERADO	2007-09	i290
1997-05	CENTURY		Classic	2007-09	i370
1995-05	LE SABRE	2003-06	SUBURBAN	Oldsmobile	
1995-05	PARK AVE	2003-06	TAHOE	1996-98	ACHIEVA
2004-07	RAINIER	1998-04	TRACKER	1999-04	ALERO
1995-04	REGAL	2002-09	TRAILBLAZER	1995-03	AURORA
2002-07	RENDEZVOUS	2000-05	VENTURE	1998-04	BRAVADA
1996-99	RIVIERA	Geo		1995-99	CUTLASS/SUPREME
1995-96	ROADMASTER	1995-97	METRO	1994-99	DELTA 88/ROYALE/88
1996-98	SKYLARK	1992-97	TRACKER	1998-02	INTRIGUE
Cadillac		GMC		1996-99	LSS
1990-96	FLEETWOOD	2004-12	CANYON	1994-96	NINETY-EIGHT
1990-92	BROUGHAM	2002-09	ENVOY	1997-98	REGENCY
1992-95	EL DORADO	2002-03	*JIMMY	2000-04	SILOUETTE
2003-06	ESCALADE/ESV	2001-07	SAVANA VAN	Pontiac	
1992-95	SEVILLE	2003-06	SIERRA	2001-05	AZTEK
Chevrolet		2007	SIERRA Classic	2000-05	BONNEVILLE
2003-06	AVALANCHE	2002	*SONOMA	2001-05	GRAND AM
2002	*BLAZER	2003-04	SONOMA	2000-05	SUNFIRE
2003-05	BLAZER	2003-06	YUKON	2000-04	MONTANA
2000-05	CAVALIER	2003-06	YUKON XL	2003-08	VIBE
2004-12	COLORADO	Honda		Suzuki	
2001-07	EXPRESS VAN	1998-02	PASSPORT	2002	AERIO
2000-05	IMPALA	Hummer		1992-98	SIDEKICK
2001-03	MALIBU	2003-06	H1	1998-02	ESTEEM
2004	MALIBU Classic	2003-07	H2/SUT	1999-02	GRAND VITARA
1998-01	METRO	Isuzu		1995-01	SWIFT
2000-05	MONTE CARLO	1998-00	AMIGO	1999-03	VITARA
2003-06	SSR	2003-08	ASCENDER	2001-02	XL-7
2002	*S-10 P/U	1998-04	RODEO	Toyota	
2003-04	S-10 P/U	2006-07	i280	2003-04	MATRIX
2003-06	SILVERADO	2006-07	i350		

BRACKET PREPARATION

For All Vehicles Not Including

1990-96 Fleetwood/Brougham

Remove the (2) top and the (2) bottom mounting tabs on the back edges of the top & bottom of main bracket. Bottom tabs not shown.

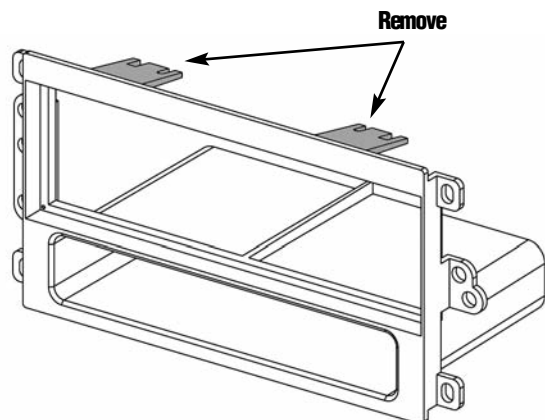

KIT ASSEMBLY INSTRUCTIONS

Single DIN Mount Applications

1. Insert DIN sleeve from your new radio into the upper section of the installation kit.
2. Depress the tabs from inside the sleeves opening upward, outward, and downward to secure sleeve to the installation kit.
3. Install radio into sleeve and lock into place.
4. Attach a rear support bracket to the rear of the new radio and adjust as necessary to attach to the rear support stud located on the back of the pocket using the small phillips screw supplied with kit.

NOTE: ISO trim ring (GM-K420) may be used in place of after-market radio's removable trim ring.

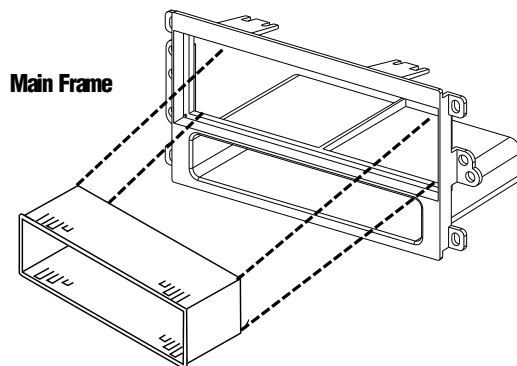

KIT ASSEMBLY

For DIN and ISO Mount applications

ATTACH LEFT AND RIGHT IMB-420 BRACKETS TO THE MAIN BRACKET AS SHOWN IN ILLUSTRATION. THEN SECURE SIDE BRACKETS TO THE BACK OF THE POCKET USING 2 SMALL SCREWS PROVIDED WITH KIT.

INSERT SPACERS INTO BRACKETS ON BOTH SIDES ONLY WHEN ISO MOUNTING RADIO

NOTE: Some modifications to ISO brackets may be necessary due to obstruction in some vehicles subdash.

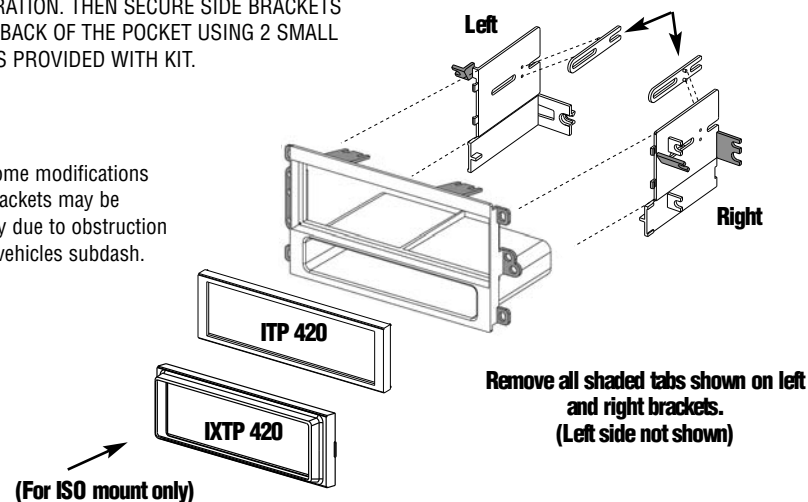

2003-06 GM AVALANCHE, CLASSIC, SILVERADO, TAHOE

DASH DISASSEMBLY

1. Engage the parking brake.
2. Tilt the steering wheel to its lowest position.
3. Insert the ignition key into the ignition switch, and then turn the ignition switch to the ON position. Do not start the engine! (Not required for manual shift vehicles).
4. Depress the brake pedal and adjust the shift lever to the lowest gear position (not required for manual shift vehicles).

MAIN BRACKET PREPARATION

FIG. A

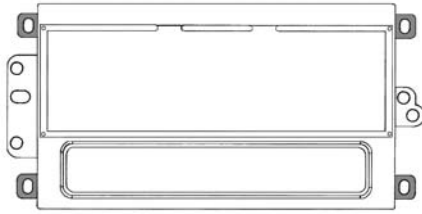

****FOR BELOW APPLICATIONS, BREAK OFF SHADED BRACKETS (SEE FIG. A)**

Buick	Cadillac	SILVERADO		DELTA
CENTURY	ESCALADE	SSR		
LA SABRE	Chevrolet	SUBURBAN	Hummer	88/ROYALE
PARK AVE	BLAZER	TAHOE	H1	INTRIGUE
RAINIER	CAVALIER	VENTURE	H2/SUT	L SS
REGAL	COLORADO	GMC	ACHIEVA	NINETY-EIGHT
REGENCY	EXPRESS VAN	CANYON	ALERO	SILOUETTE
RENDEZVOUS	IMPALA	ENVOY	AURORA	PONTIAC
RIVIERA	MALIBU	JIMMY	BRAVADA	AZTEK
ROADMASTER	MONTE CARLO	SIERRA	CUT-	BONNEVILLE
SKYLARK	S-10 P/U	YUKON	LASS/SUPRE	GRAND AM
		XL	E	MONTANA

FIG. B

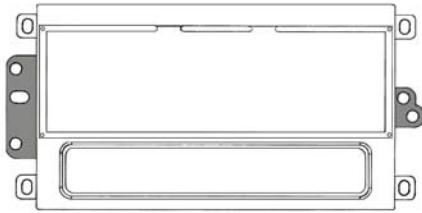

****FOR BELOW APPLICATIONS, BREAK OFF SHADED BRACKETS (SEE FIG. B)**

Chevy/GEO	SIDEKICK
METRO	SWIFT
TRACKER	GRAND
Suzuki	VITARA
AERIO	VITARA
ESTEEM	XL-7

FIG. C

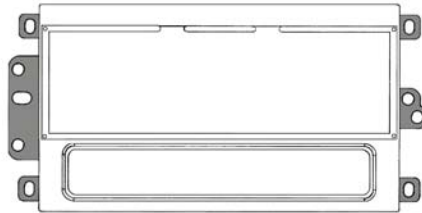

****FOR BELOW APPLICATIONS, BREAK OFF SHADED BRACKETS (SEE FIG. C)**

Cadillac	Honda	Toyota
EL DORADO	PASSPORT	MATRIX
FLEETWOOD/	Isuzu	Pontiac
BROUGHAM	AMIGO	VIBE
SEVILLE	RODEO	

Note: For shaft radio applications, part number USK-400 is required

FOR ALL VEHICLES NOT LISTED BELOW

*See page 4 for your vehicles main bracket Preparation

1998-02 Honda Passport
 1998-00 Isuzu Amigo
 1998-04 Isuzu Rodeo
 2003-08 Pontiac Vibe
 2003-04 Toyota Matrix

1992-95 Cadillac Applications

KIT ASSEMBLY

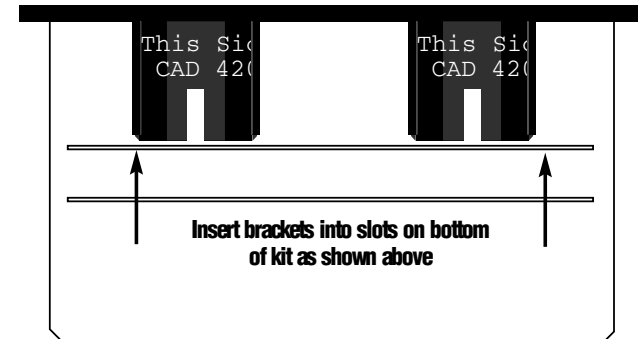

DASH DISASSEMBLY INSTRUCTIONS

- 1) Starting from the bottom of the Radio trim bezel, carefully pry outward on the dash trim bezel to unclip the lower edge and sides.
- 2) Angle the dash trim bezel outward from the bottom and pull the top of the panel down to unfasten the two upper tabs.
- 3) Pull the trim bezel forward and disconnect all harnesses attached to the panel and remove panel.
- 4) Remove the harness clamp attached at the rear of the left factory radio bracket.
- 5) Remove the (4) 10mm bolts securing the factory radio to the sub-dash.
- 6) Pull radio forward, disconnect the wire harness and antenna lead and remove radio.

KIT ASSEMBLY

For DIN and ISO Mount applications

ATTACH LEFT AND RIGHT IMB-420 BRACKETS TO THE MAIN BRACKET AS SHOWN IN ILLUSTRATION. THEN SECURE SIDE BRACKETS TO THE BACK OF THE POCKET USING 2 SMALL SCREWS PROVIDED WITH KIT.

NOTE: Some modifications to ISO brackets may be necessary due to obstruction in some vehicles subdash.

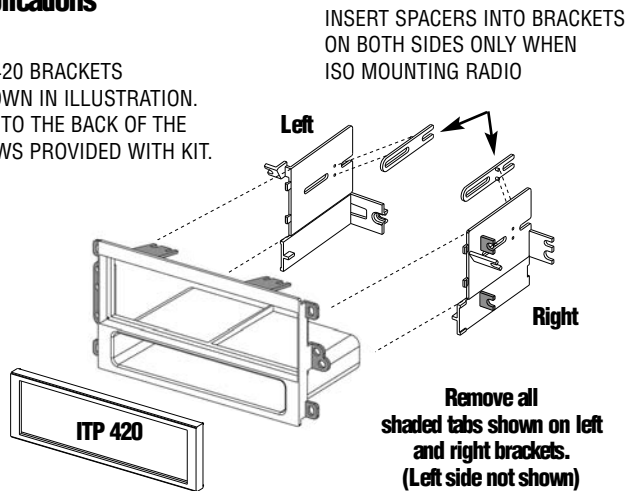

1998-02 Honda/Isuzu Applications

DASH DISASSEMBLY INSTRUCTIONS

- 1) Open ashtray and remove ashtray cup.
- 2) Remove (1) phillips screw from rear of ashtray cavity.
- 3) Carefully unclip trim bezel from around radio/lighter assembly.
- 4) Disconnect wire harness from lighter and remove trim assembly.
- 5) Remove the (4) phillips screws securing radio to subdash.
- 6) Pull radio forward, disconnect the wire harness and antenna lead and remove radio.

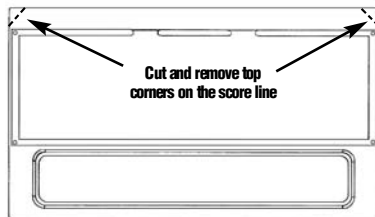

FOR ISO MOUNT APPLICATIONS ONLY

ATTACH LEFT AND RIGHT IMB-420 BRACKETS TO THE MAIN BRACKET AS SHOWN IN ILLUSTRATION. THEN SECURE SIDE BRACKETS TO THE BACK OF THE POCKET USING 2 SMALL SCREWS PROVIDED WITH KIT.

INSERT SPACERS INTO BRACKETS ON BOTH SIDES ONLY WHEN ISO MOUNTING RADIO

NOTE: Some modifications to ISO brackets may be necessary due to obstruction in some vehicles subdash.

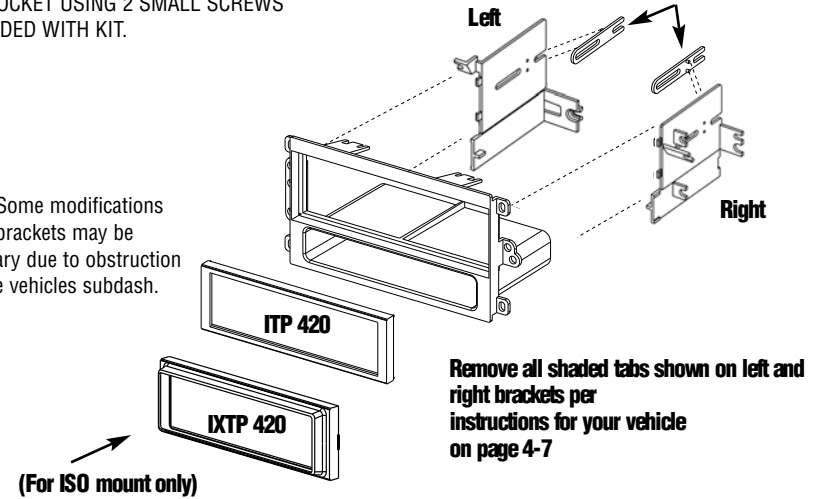

1990-1996 CADILLAC FLEETWOOD 1990-1992 CADILLAC FLEETWOOD BROUGHAM

DASH DISASSEMBLY INSTRUCTIONS

1. Carefully unclip the dash trim bezel from above the climate controls.
2. Remove the (2) screws securing the top of the Radio/climate control trim bezel, carefully unclip and remove bezel.
3. Remove the (4) screws securing the radio to the sub-dash.
4. Carefully slide radio out of the dash, disconnect all wire harnesses and antenna lead (if applicable) and remove radio.
5. Remove the top and bottom mounting brackets from the factory radio; you will need to attach these brackets to the installation kit following the instructions in the kit.

FACTORY BRACKET ATTACHMENT INSTRUCTIONS

1. Attach top factory mounting bracket (using carriage bolts and nuts supplied with kit) to top edge of kit.
2. Attach bottom factory mounting bracket (using carriage bolts and nuts supplied with kit) to bottom edge of kit.



View of the Top Edge



View of the Bottom Edge